

# Modular Work Centers

## 2 & 3 Drawer Pedestal (D-9011, D-9012, D-9013)

CALSTONE INC - 020107

### Component Parts:

- 1 - Drawer Cabinet c/w Drawers
- 1 - Drawer Mounting Frame
- 1 - Locking Plate
- 8 - #10 x 5/8" Combination Screws

*(Inspected by)*

NOTE: If hardware is missing, any #10 x 5/8" self-tapping screws can be used.

### Pedestal Drawer Assembly:

1. All tops are pre-drilled, right and left side, to accept drawer mounting frame.
2. Lift drawer mounting frame to underside of table top in desired location. **MAKE SURE FRAME BUTTS AGAINST BACK OF UPPER CHANNEL.** Install #10 combination screws and tighten.
3. Slide channels on top of drawer module onto previously installed mounting frame and push toward back of table until sealed.
4. Open top drawer and align holes on locking plate with holes on front flange of drawer mounting frame. Install #10 combination screws to secure locking plate.

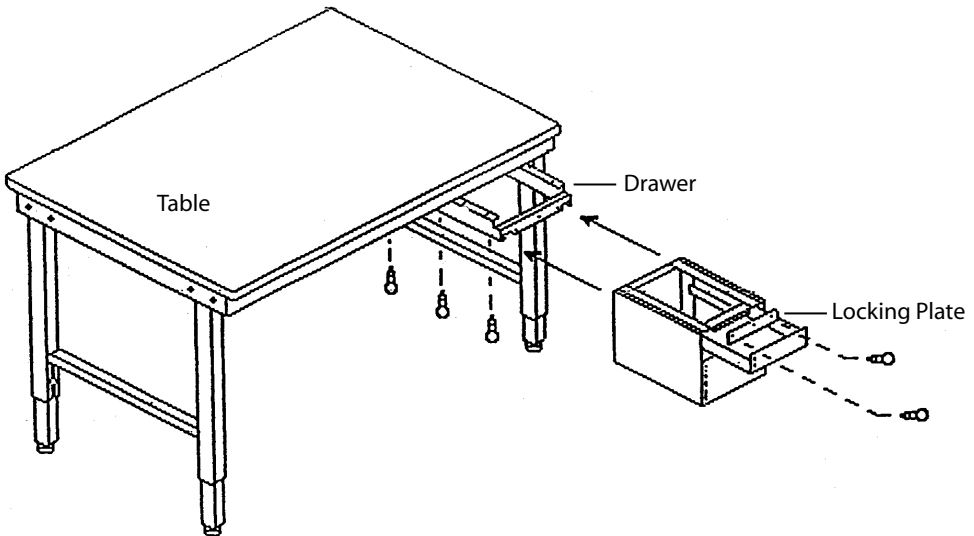

\*Do not discard packaging material until all contents are located\*

300 S. Lageschulte St.  
Barrington, IL 60010  
Phone: 847.382.1579 Fax: 847.382.1615  
E-mail: info@dehnco.com