

Modular Work Centers

Lift Table (D-9006)

CALSTONE INC - 020107

Component Parts:

- 1 - Table Top with Frame
- 2 - Crank Leg Assembly
- 1 - Back Panel
- 1 - Connecting Rod
- 1 - Crank Handle
- 8 - 5/16-18 x 2-1/4" Hex Bolts
- 8 - 5/16-18 x 2-1/4" Hex Nut and Washer
- 4 - #10-24 x 1/2 Machine Screws

(Inspected by)

NOTE: If hardware is missing, any 5/16-18 x 2-1/4" or 2-1/2" long bolt, hex nut, and lock washer can be used.

Lift Table Assembly:

1. Assembly crank leg assembly to table using hex bolt and nuts, hand tighten only.
2. Insert connecting rod into gear box fitting on crank leg, line up connecting rod with free leg an carefully push leg assembly in to the table channel. Crank may have to be turned to line up with connecting rod.
3. Install hex bolt and nuts, hand tighten only.
4. Install back panel with 4 screws - #10-24 x 1/2.
5. Tighten all screws.

TURN HANDLE CLOCKWISE TO RAISE;
COUNTER-CLOCKWISE TO LOWER.

CAUTION: Do not force crank after the table has reached the upper or lower limit.

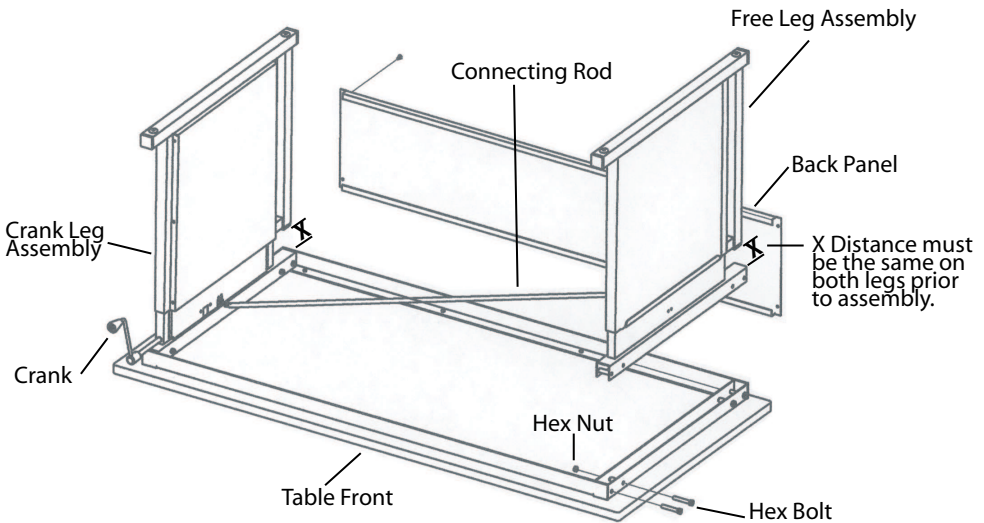

Do not discard packaging material until all contents are located