

Modular Work Centres

Economy Table (D-9004 & D-9004A)

CALSTONE INC - 020107

Component Parts:

- 1 - Table Top
- 2 - Table Legs
- 2 - Front and Back Aprons
- 20 - #10 x 5/8 Combination Screws
- 1 - Wrench

(Inspected by)

NOTE: If hardware is missing, any #10 x 5/8 self-tapping screw can be used.

Economy Table Assembly:

1. Place table top upside down.
2. Line up table legs with the holes in the table top and fasten loosely with #10 x 5/8 combination screws.
3. Repeat for other table leg.
4. Install front and back apron to leg tubes and table top with #10 x 5/8 combination screws.
5. Tighten all the screws.

Table Height Adjustment (for D-9004A only)

1. Adjustable leg channel on each leg member telescopes out and is notched every inch to make adjustment easy.
2. To adjust, loosen bolt on leg member and raise adjustable leg to the desired height. Set all four legs to the same height, secure bolt.
3. Turn table upright to operating position.

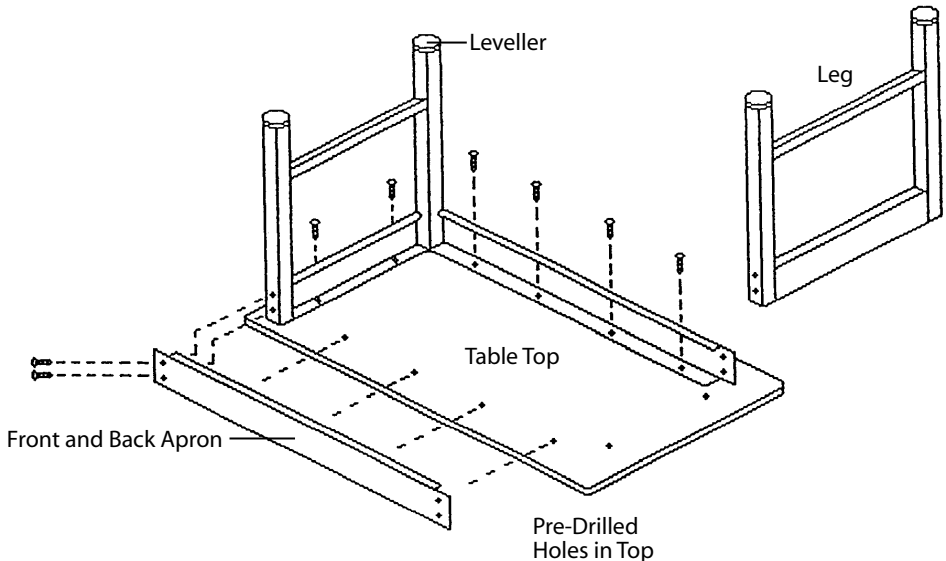

Do not discard packaging material until all contents are located