

# Modular Work Centres

## Packing Tables (D-9000 & D-9001)

CALSTONE INC - 020107

### Component Parts:

- 1 - Table Top with Frame
- 2 - Table Legs
- 8 - 5/16-18 x 2-1/4" Hex Cap Screws
- 8 - 5/16 Lock Washers
- 4 - Spacer Tubes
- 1 - Wrench

*(Inspected by)*

NOTE: If hardware is missing, any 5/16-18 x 2-1/4" or 2-1/2" long bolt, hex nut, and lock washer can be used.

### Packing Table Assembly:

1. Place table top on floor with channels facing up.
2. Press leg frame into table top frame so holes line up, as shown.
3. Install two spacer tubes on the inside of each leg assembly.
4. Secure leg frame with nuts, bolts, and washers supplied in plastic bag on table.
5. Repeat steps 2-4 for second leg assembly.

### Table Height Adjustment:

1. Adjustable leg channel on each leg member telescopes out and is notched every inch to make adjustment easy.
  2. To adjust, loosen bolt on leg member and raise adjustable leg to the desired height; secure bolt.
  3. Turn table upright to operating position.
- NOTE: If optional drawer or cabinet has been ordered, secure mounting frame BEFORE putting table in operating position.
4. Minor height adjustments can be made by using the screw-type leveller on each adjustable leg channel or by resetting the telescope leg.

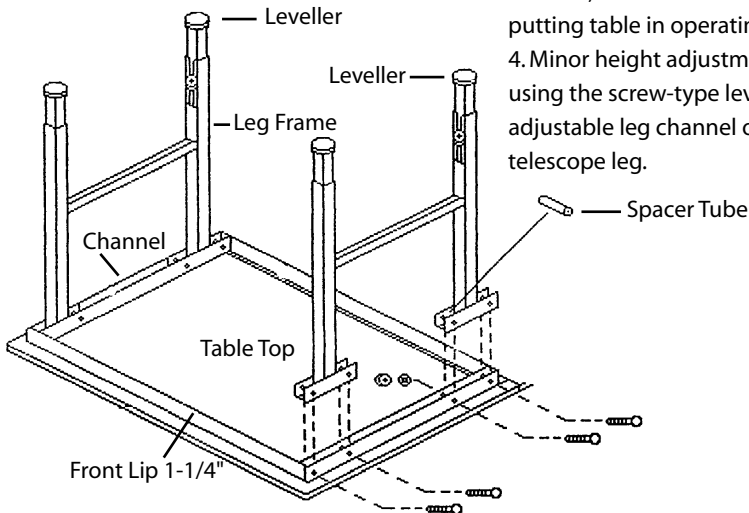

\*Do not discard packaging material until all contents are located\*