

Modular Work Centers

Portable Carton Rack (D-9060)

CALSTONE INC - 020107

Component Parts:

- 1 - Portable Carton Rack 18 x 44
- 5 - Wire Dividers
- 10 - 1/2"-13 Hex Nut
- 20 - 1/2" Flat Washers
- 4 - 3/8"-16 x 1-1/4" Levellers

(Inspected by)

Carton Rack Assembly:

1. Place portable carton rack on floor with threaded holes facing up, and screw levellers into threaded holes.
2. Turn portable carton rack onto levellers.
3. Insert dividers (5 provided) where desired.
4. Turn portable carton rack, complete with dividers in place, onto its side.
5. From bottom of portable carton rack, place washer onto dividers and secure tightly with nuts.
6. Turn portable carton rack, with dividers in place, upright.

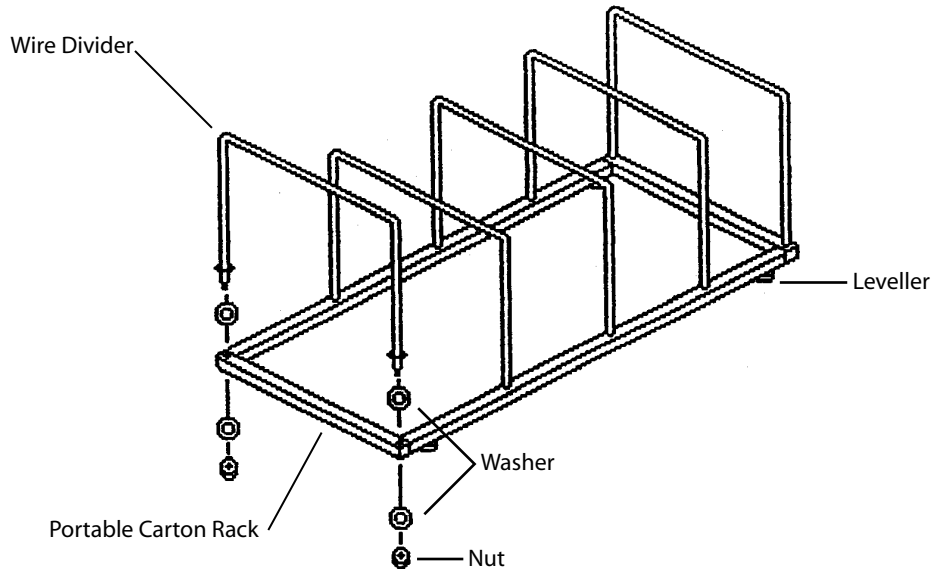

Do not discard packaging material until all contents are located

Modular Work Centers

Metal 1-Drawer Unit (D-9010N) / Lock (D-9015)

CALSTONE INC - 020107

Component Parts:

- 1 - Metal 1-Drawer Unit
- 1 - Drawer Casing
- 2 - Mounting Brackets
- 8 - #10 x 5/8" Combination Screws
- 6 - 1/4 x 3/4 Screws

(Inspected by)

Metal 1-Drawer Unit Assembly:

1. All tops are pre-drilled, RIGHT and LEFT side, to accept mounting brackets.
 2. Assemble mounting brackets with #10 combination screws to table, as shown.
 3. Remove drawer from casing by pulling drawer half way out, ready inside and pull down drawer stop.
 4. Assemble drawer casing to mounting bracket with 1/4 x 3/4 screws.
 5. Slide drawer back into casing.
- NOTE: INSTALLATION IS EASIER IF TABLE IS UPSIDE DOWN.*

Lock for Metal 1-Drawer Unit (Optional):

1. Punch out depression in drawer unit front.
2. Disassemble all parts of lock - 7 pieces total.
3. Insert tube part of lock into punched out depression in drawer unit from outside of drawer.
4. Place nut onto tube from inside of drawer unit and tighten.
5. Place key into key receive and then insert receiver into tube part, already in drawer.
6. Place washer and flat bar into tube and secure firmly with screw.

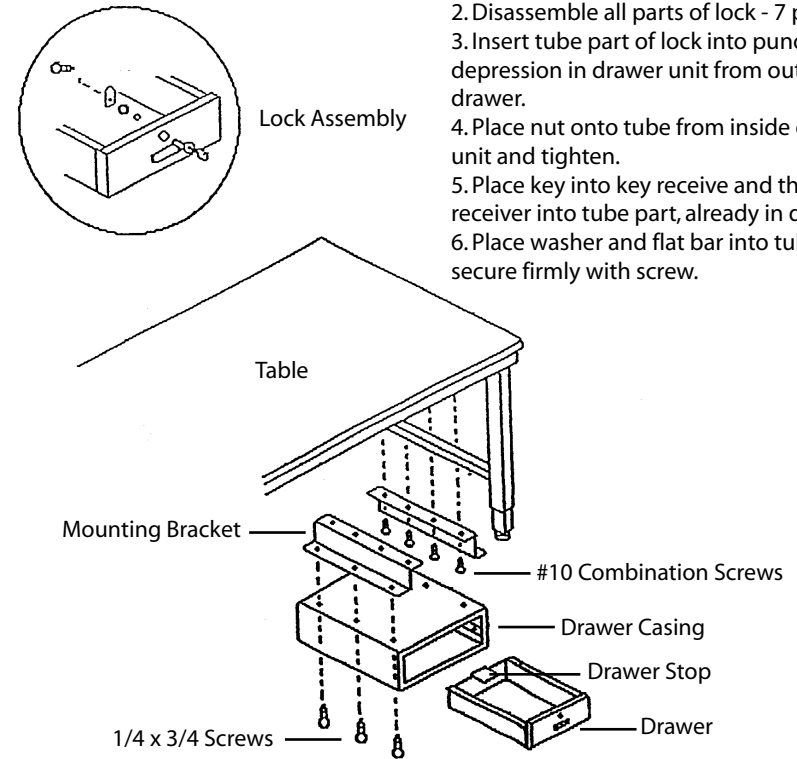

Do not discard packaging material until all contents are located

Modular Work Centers

2 & 3 Drawer Pedestal (D-9011, D-9012, D-9013)

CALSTONE INC - 020107

Component Parts:

- 1 - Drawer Cabinet c/w Drawers
- 1 - Drawer Mounting Frame
- 1 - Locking Plate
- 8 - #10 x 5/8" Combination Screws

(Inspected by)

NOTE: If hardware is missing, any #10 x 5/8" self-tapping screws can be used.

Pedestal Drawer Assembly:

1. All tops are pre-drilled, right and left side, to accept drawer mounting frame.
2. Lift drawer mounting frame to underside of table top in desired location. **MAKE SURE FRAME BUTTS AGAINST BACK OF UPPER CHANNEL.** Install #10 combination screws and tighten.
3. Slide channels on top of drawer module onto previously installed mounting frame and push toward back of table until sealed.
4. Open top drawer and align holes on locking plate with holes on front flange of drawer mounting frame. Install #10 combination screws to secure locking plate.

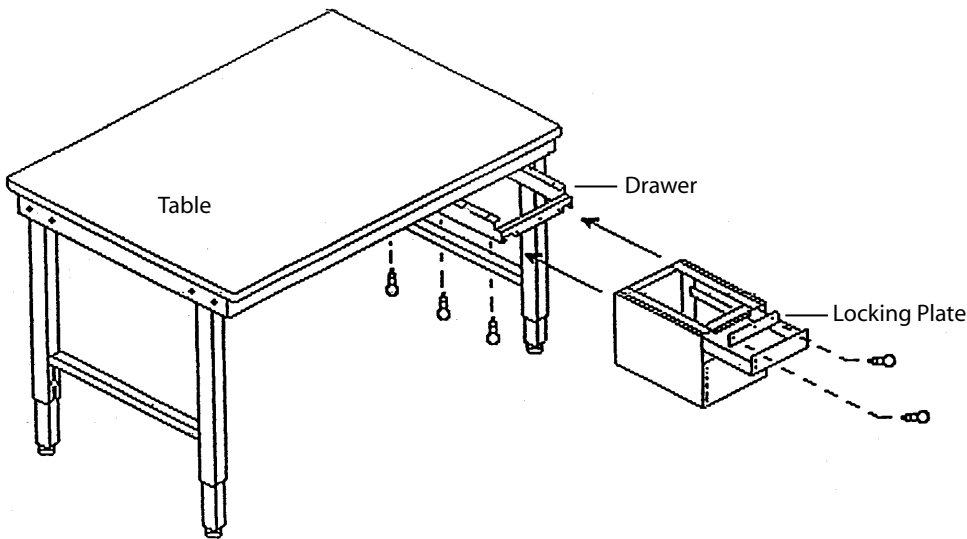

Do not discard packaging material until all contents are located

Modular Work Centers

Cartoning Rack c/w 6 Dividers & T-Uprights (D-9031)

CALSTONE INC - 020107

Component Parts:

- 1 - Cartoning Rack
- 6 - Wire Dividers
- 2 - T-Uprights with Adjustable Brackets
- 24 - 1/4" Flat Washers
- 12 - 3/8-16 Hex Nuts
- 4 - 1/4-20 x 1/2" Round Head Bolts
- 4 - 1/4-20 Kepnuts
- 4 - 5/16-18 x 2-1/4" Hex Head Cap Screws
- 4 - 5/16-18 Hex Nuts
- 4 - 5/16 Lock Washers

(Inspected by)

T-Upright Assembly:

1. Place welded bracket on leg frame, as shown. Slide upright up or down to desired height.
2. Secure welded bracket with 2-1/4" screws, washers and nuts provided.
3. Attach second T-Upright, making sure it is positioned at the same height as the first.

Cartoning Rack Assembly:

1. Place Cartoning Rack on T-Uprights, as shown.
2. Align pre-drilled holes in cartoning rack with holes in T-Uprights. Front edge of cartoning rack should stick out over table approximately 9 inches. NOTE: If the majority of the cartoning rack hangs over the back edge of table, turn assembly 180 degrees and reposition on T-Upright.
3. Secure cartoning rack to T-Upright with 1/4-20 screws and kepnuts.

Divider Placement:

1. Place washer over end of divider so it rests against notches on the wire, as shown.
2. Put ends of wire divider through holes on cartoning rack, as shown.
3. Place another washer over wire ends and secure with 3/8-16 hex nuts.
4. Do not over tighten. The wires should not protrude out of the hex nuts.

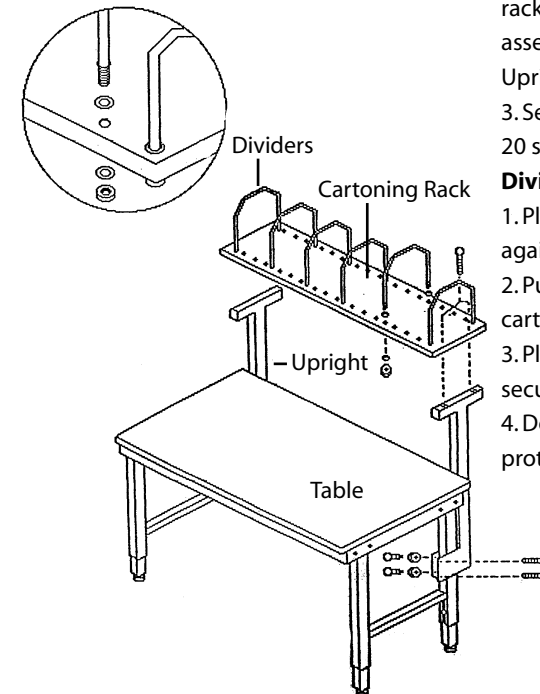

Do not discard packaging material until all contents are located

Modular Work Centers

Slat Wall (D-9050) & Accessories (D-9051, D-9052, D-9053)

CALSTONE INC. - 020107

Component Parts:

- 1 - Slat Wall 12 x 58-1/2
- 4 - Mounting Brackets
- 4 - 5/16-18 x 2-1/4 Hex Head Cap Screw
- 4 - 5/16-18 Hex Nuts
- 4 - 5/16 Lock Washers
- 4 - Spacer Tubes

Slat Wall Assembly:

1. Place Slat Wall on table with grooves facing front of table.
2. Slide mounting brackets onto uprights (two mounting brackets on each up-right).
3. Slide Slat Wall between mounting brackets. Match Slat Wall holes with outside holes on mounting bracket.
4. Push screw through mounting bracket and Slat Wall. Insert spacer tube between Slat Wall and back of mounting bracket. Push screw all the way through and install washer and nut loosely. Repeat until all 4 corners are mounted.
5. Slide Slat Wall and mounting brackets to desired height on uprights and tighten securely.

(Inspected by)

NOTE: If hardware is missing, any 5/16-18 x 2-1/4" or 2-1/2" long bolt, hex nut and lock washer can be used.

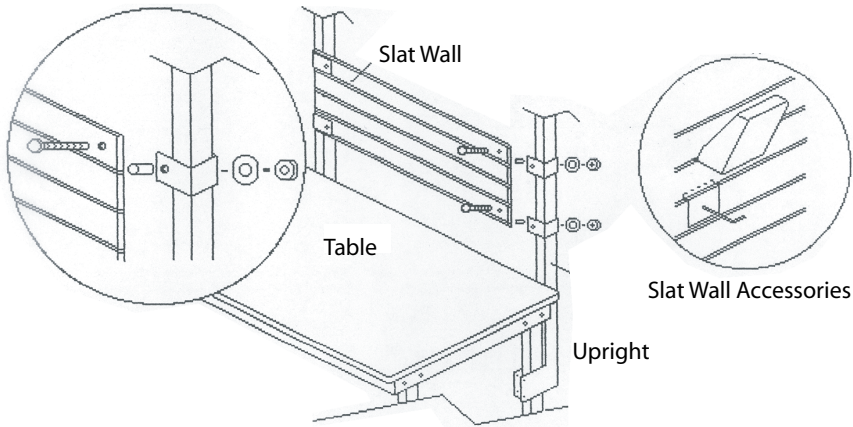

Slat Wall Accessories Contents:

- 1 - Slat Wall Hook OR
- 1 - Slat Wall Small Bin OR
- 1 - Slat Wall Literature Shelf

Slat Wall Accessories Assembly:

1. Take item with "L" angle at top and back.
2. Lift item up so that "L" angle fits into Slat Wall slat.
3. Lower item to be flush with Slat Wall. The "L" angle will catch in slat and fit securely.
4. Locate item where desired.

Do not discard packaging material until all contents are located