

Modular Work Centers

Roll Bar for Tables (D-9030)

CALSTONE INC - 020107

Component Parts:

- 1 - Roll Bar
- 2 - Mounting Brackets
- 2 - Core Retainers
- 2 - 5/16-18 x 2-1/4" Hex Head Cap Screws
- 2 - 5/16-18 Hex Nuts
- 2 - 5/16 Lock Washers

(Inspected by)

NOTE: If hardware is missing, any 5/16-18 x 2-1/4" or 2-1/2" long bolt, hex nut and lock washer can be used.

Roll Bar Assembly for Above Table

Mounting:

1. Place roll bar bracket around upright tubing so that upper U-hook is facing up and toward the back, and is on the inside of the upright assembly, as shown.
2. Attach second bracket as above, making sure the brackets are the same height.
3. Place roll bar insert into Upper U-hook on both brackets. Level brackets, if necessary.

Roll Bar Assembly for Below Table Mounting:

1. Place roll bar bracket around leg assembly cross bar with U-hook facing up, and on the inside of leg assembly cross bar, as shown.
2. Attach second bracket as above, making sure the brackets are spaced the same.
3. Place roll bar insert into upper U-hook on both brackets.

Bracket Mounting
ABOVE Table

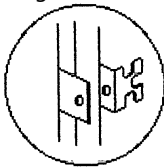

Bracket Mounting
BELOW Table

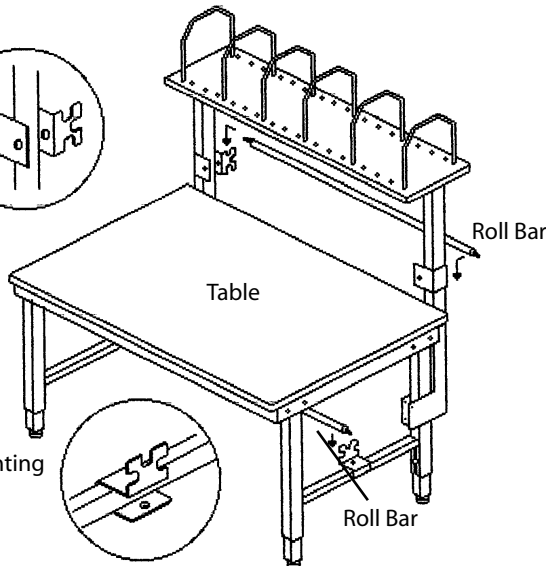
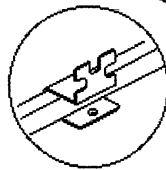

Do not discard packaging material until all contents are located