

Modular Work Centers

Slide Out Keyboard (D-9094)

CALSTONE INC - 020107

Component Parts:

- 1 - Keyboard Slide Out Unit Tray
- 2 - Rubber Bumpers
- 2 - 1/4" x 3/4" Screws
- 2 - 1/4" Nuts

Keyboard Slide Out Assembly:

1. Stick rubber bumper on the top of the tray.
2. Insert this end into the channel of the shelf.
3. Install this end using 1/4" x 3/4 screws and nuts.

(Inspected by)

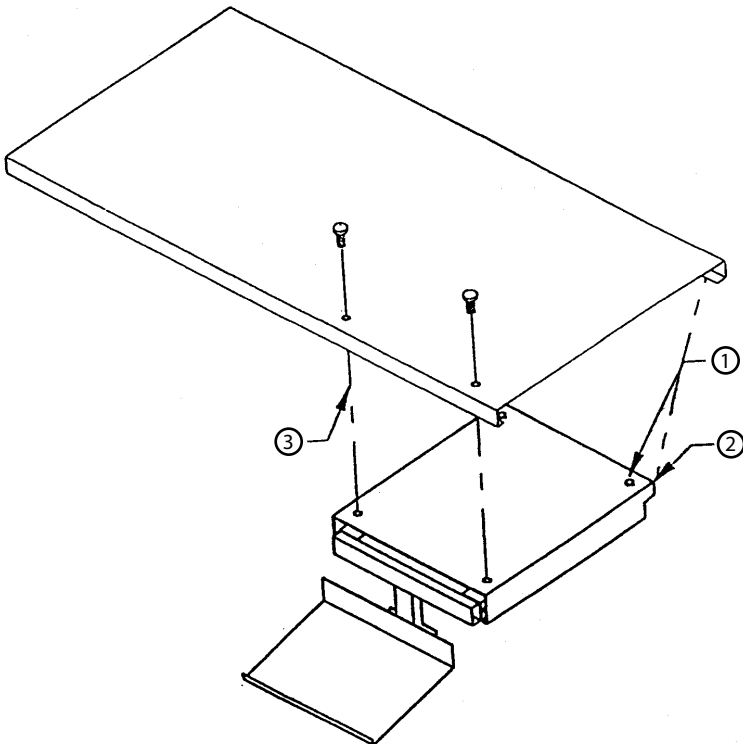

Do not discard packaging material until all contents are located

300 S. Lageschulte St.
Barrington, IL 60010
Phone: 847.382.1579 Fax: 847.382.1615
E-mail: info@dehnco.com