

Modular Work Centers

Roll Storage Stand

CALSTONE INC. - 020107

Component Parts:

- 2 - Side Frame
- 2 - Side Frame Upright
- 1 - Base
- 1 - Roll Bar
- 2 - Roll Bar Bracket
- 4 - Adjustable Glides 3/8-16 x 1-1/2"
- 2 or 4 - Assembly Nut 3/8-16
- 2 or 4 - 3/8-16 x 3/4 Hex Head Cap Screw
- 4 - 5/16-18 x 2-1/4" Hex Head Cap Screw
- 4 - 5/16-18 Hex Nut
- 0 or 1 - #10 x 5/8 Combination Screw

Roll Storage Stand Assembly:

1. Fasten base to side frame with 5/16-18 x 2-1/4 Hex Head Cap Screws.
2. Adjust side frame up-rights to desired height and tighten bolts
3. Install Roll Bar Brackets, as shown, with 5/16-18 x 2-1/4 Hex Head Cap Screws and Nuts.

NOTE: 2 sets of 5/16-18 x 2-1/4" Hex Head Cap Screw, and Hex Nut are packed with Roll Bar Bracket.

(Inspected by)

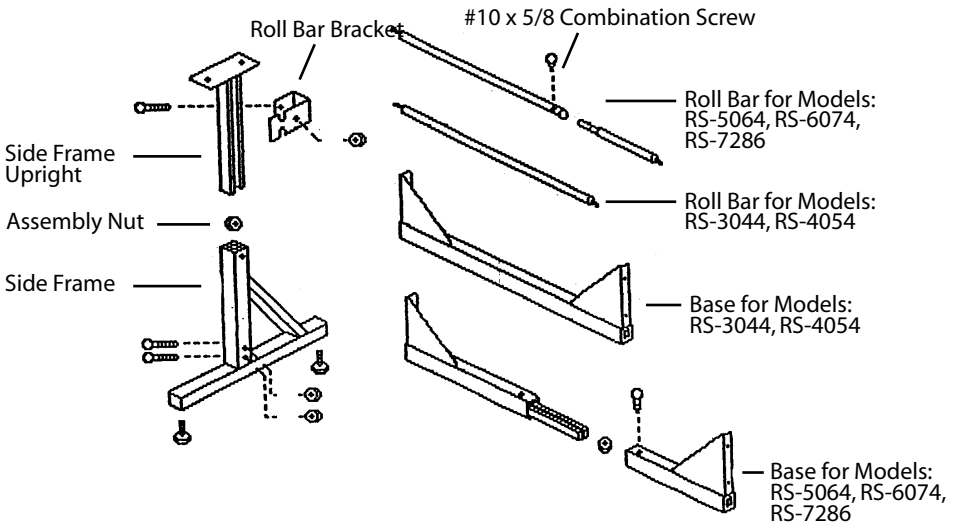

Do not discard packaging material until all contents are located