

# Modular Work Centers

## RC Rotary Shear Cutter & Knife Assembly

CALSTONE INC - 020107

### Component Parts:

- 1- Cutter Bar & Knife Assembly
- 4 - 1/4-20 x 1-1/2 Combination Screw
- 4 - 1/4 Lock Washer
- 4 - 1/4-20 Hex Nut

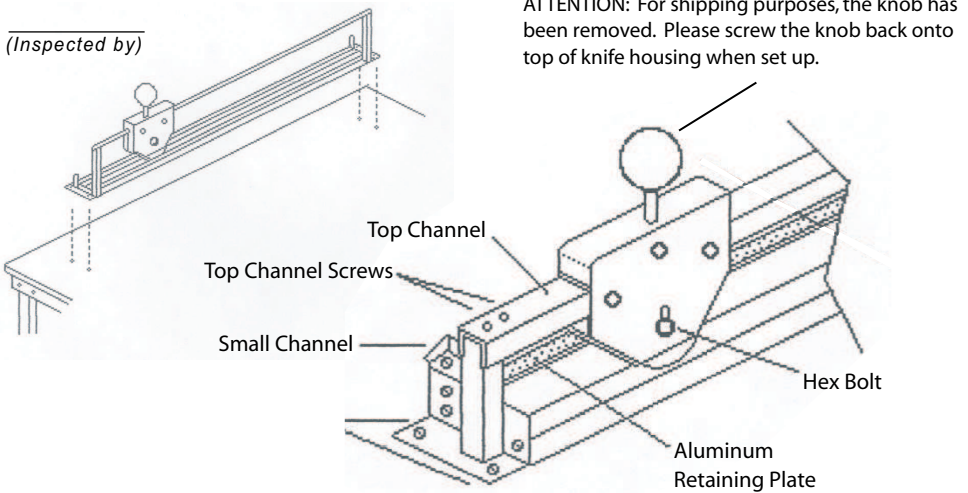

### Cutter Bar & Knife Assembly:

1. Place cutter bar & knife assembly on table top with logo facing front. Centre between leg frames and place at least 4" from back of table top to back of cutter bar & knife assembly.
2. Mark holes through the base tube and remove cutter bar & knife assembly.
3. Drill holes into table top with 9/32" drill bit.
4. Replace cutter bar & knife assembly, matching holes, and secure with 1-1/2" screws through base tube and table top, and tighten with washer and nut.

*NOTE: Both ends of the cutter must be fastened securely in order for the cutter to work properly.*

\*Do not discard packaging material until all contents are located\*