

# Modular Work Centers

## Cartoning Rack c/w 6 Dividers & T-Uprights (D-9031)

CALSTONE INC - 020107

### Component Parts:

- 1 - Cartoning Rack
- 6 - Wire Dividers
- 2 - T-Uprights with Adjustable Brackets
- 24 - 1/4" Flat Washers
- 12 - 3/8-16 Hex Nuts
- 4 - 1/4-20 x 1/2" Round Head Bolts
- 4 - 1/4-20 Kepnuts
- 4 - 5/16-18 x 2-1/4" Hex Head Cap Screws
- 4 - 5/16-18 Hex Nuts
- 4 - 5/16 Lock Washers

(Inspected by)

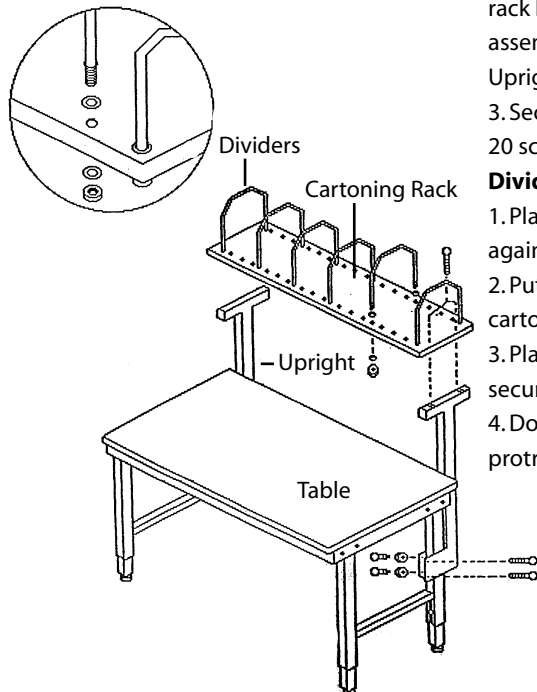

\*Do not discard packaging material until all contents are located\*

### T-Upright Assembly:

1. Place welded bracket on leg frame, as shown. Slide upright up or down to desired height.
2. Secure welded bracket with 2-1/4" screws, washers and nuts provided.
3. Attach second T-Upright, making sure it is positioned at the same height as the first.

### Cartoning Rack Assembly:

1. Place Cartoning Rack on T-Uprights, as shown.
2. Align pre-drilled holes in cartoning rack with holes in T-Uprights. Front edge of cartoning rack should stick out over table approximately 9 inches. NOTE: If the majority of the cartoning rack hangs over the back edge of table, turn assembly 180 degrees and reposition on T-Upright.
3. Secure cartoning rack to T-Upright with 1/4-20 screws and kepnuts.

### Divider Placement:

1. Place washer over end of divider so it rests against notches on the wire, as shown.
2. Put ends of wire divider through holes on cartoning rack, as shown.
3. Place another washer over wire ends and secure with 3/8-16 hex nuts.
4. Do not over tighten. The wires should not protrude out of the hex nuts.